

# K91 TYPE -40°C +85°C 15000H

RoHS Compliant

- Design optimized for low equivalent series resistance and high ripple current.
- Surge-proof capacitor in aluminium can with insulation sleeve.
- To be mounted with ring clips or with threaded stud.

## APPLICATIONS

Designed for professional application.  
Switch mode power suppliers, high ripple current converters, motor drives.

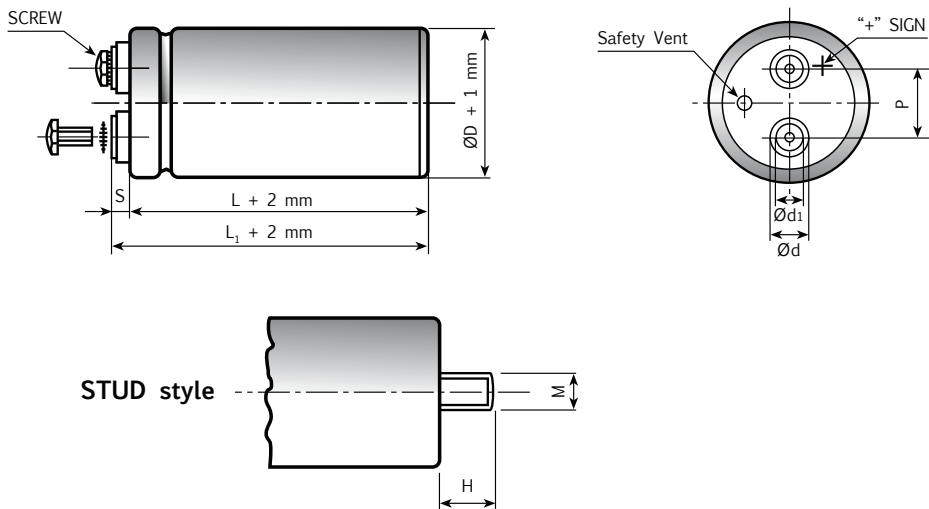

Diagram of dimensions (unit=mm)  
Insert and screw threads: Metric (mm), UNF (inches)

ØD	d	d1	P	STUD M	H	INSERT	SCREW	L <sub>1</sub> -L[-1+3]	S[-1+1]	INSERT STYLE CODE
35	11	7.9	12.7	M8	12	M5	5MA x 9.5	2.5	5	0
51	18.5	13	22.7	M12	16	M5	5MA x 9.5	2.5	5	H
63	18.5	13	28.6	M12	16	M5	5MA x 9.5	2.5	5	H
63	17.3	17.3	28.6	M12	16	UNF 1/4-28 Low Post	1/4-28 x 3/8"	3	4	W
63	17.3	17.3	28.6	M12	16	UNF 1/4-28 High Post	1/4-28 x 1/2"	6	7	R
63	7.9	7.9	28.6	M12	16	UNF 10-32 Low Post	10-32 x 1/4"	2	2.5	Z
63	12	7.9	28.6	M12	16	UNF 10-32 High Post	10-32 x 3/8"	6	7	U
76	18.5	13	31.8	M12	16	M5	5MA x 9.5	2.5	5	H
76	18.5	13	31.8	M12	16	M5	5MA x 9.5	2.5	7	L
76	23.2	17.7	31.8	M12	16	M6	6MA x 10	4.5	7	6
76	17.3	17.3	31.8	M12	16	UNF 1/4-28 Low Post	1/4-28 x 3/8"	3	4	W
76	17.3	17.3	31.8	M12	16	UNF 1/4-28 High Post	1/4-28 x 1/2"	6	7	R
76	7.9	7.9	31.8	M12	16	UNF 10-32 Low Post	10-32 x 1/4"	2	2.5	Z
76	12	7.9	31.8	M12	16	UNF 10-32 High Post	10-32 x 3/8"	6	7	U
90	23.2	17.7	31.8	M12	16	M6	6MA x 10	4.5	7	H

## SPECIFICATIONS

<b>Temperature Range</b>	Operating : -40°C +85°C [ Environmental classification 40/85/56 IEC-68 ] Storage : Preferably below +25°C, not exceeding +40°C																																							
<b>Rated Voltage Range (V<sub>r</sub>)</b>	from 400V to 450V DC																																							
<b>Surge Voltage (V<sub>p</sub>)</b>	V <sub>p</sub> = 1.10 V <sub>r</sub>																																							
<b>Rated Capacitance Range</b>	from 470 µF to 15000 µF																																							
<b>Capacitance Tolerance</b>	±20% at 100 Hz, 20°C [M class IEC-62] on request : -10% +30% at 100 Hz, 20°C [Q class IEC-62]																																							
<b>Leakage Current (I<sub>L</sub>) (mA, 5 min, 20°C)</b>	max I <sub>L</sub> = 0.006 C <sub>r</sub> V <sub>r</sub> + 4 µA																																							
<b>Ripple current (I<sub>r</sub>)</b>	Refer to table at 85°C and 100Hz : <table style="width: 100%; border-collapse: collapse;"> <tr> <td style="text-align: left;">FREQUENCY</td> <td>50Hz</td> <td>100Hz</td> <td>500Hz</td> <td>1000Hz</td> <td>&gt;10kHz</td> </tr> <tr> <td style="text-align: left;">MULTIPLIER</td> <td>0.8</td> <td>1.0</td> <td>1.2</td> <td>1.3</td> <td>1.5</td> </tr> <tr> <td style="text-align: left;">AMBIENT TEMP</td> <td>35°C</td> <td>45°C</td> <td>55°C</td> <td>65°C</td> <td>75°C</td> <td>85°C</td> <td>95°C</td> </tr> <tr> <td style="text-align: left;">MULTIPLIER</td> <td>2.2</td> <td>2.1</td> <td>1.8</td> <td>1.6</td> <td>1.4</td> <td>1.0</td> <td>0.5</td> </tr> </table> <p>Due to the current load capability of the contact elements, the following limits must not be exceeded:</p> <table style="width: 100%; border-collapse: collapse;"> <tr> <td style="text-align: left;">CAPACITOR DIAMETER</td> <td>51mm</td> <td>63mm</td> <td>76mm</td> <td>90mm</td> </tr> <tr> <td style="text-align: left;">Maximum current</td> <td>30A</td> <td>40A</td> <td>50A</td> <td>70A</td> </tr> </table>		FREQUENCY	50Hz	100Hz	500Hz	1000Hz	>10kHz	MULTIPLIER	0.8	1.0	1.2	1.3	1.5	AMBIENT TEMP	35°C	45°C	55°C	65°C	75°C	85°C	95°C	MULTIPLIER	2.2	2.1	1.8	1.6	1.4	1.0	0.5	CAPACITOR DIAMETER	51mm	63mm	76mm	90mm	Maximum current	30A	40A	50A	70A
FREQUENCY	50Hz	100Hz	500Hz	1000Hz	>10kHz																																			
MULTIPLIER	0.8	1.0	1.2	1.3	1.5																																			
AMBIENT TEMP	35°C	45°C	55°C	65°C	75°C	85°C	95°C																																	
MULTIPLIER	2.2	2.1	1.8	1.6	1.4	1.0	0.5																																	
CAPACITOR DIAMETER	51mm	63mm	76mm	90mm																																				
Maximum current	30A	40A	50A	70A																																				
<b>Insulation Resistance</b>	At 100V DC for 1 min is >100 MΩ across insulating sleeve and terminals.																																							
<b>Vibration Resistance</b>	Frequency range : 10 Hz to 55 Hz, amplitude 0.75 mm Capacitor length ≤ 143 : max acceleration 10g for 3x2 h Capacitor length > 143 : max acceleration 5g for 3x0.5 h																																							
<b>Life test</b>	After 2,000 hours application of rated voltage at 85°C capacitors meet characteristics aside	Cap change ≤ 10% tan δ ≤ 130% Leakage current (I <sub>L</sub> ) < initial limit Impedance (Z) ≤ 130%																																						
<b>Shelf life</b>	After leaving capacitors under no load for 2000 hours at 85°C, when restored at 20°C meet specifications aside	Cap change ≤ ±15% tan δ ≤ 150% Leakage current (I <sub>L</sub> ) < initial limit																																						
<b>Useful life (85°C, V<sub>n</sub>, I<sub>r</sub> applied)</b>	> 15.000 h at 85°C																																							
<b>Operation up to 105°C with voltage derating 0,88 x V rated</b>																																								
<b>Failure percentage Failure rate</b>	≤ 1% (during useful life) ≤ 33 fit (33 10 <sup>-9</sup> /h)																																							
<b>Self inductance</b>	Approx. 20 nH																																							
<b>Reference standards</b>	CECC 30.300 IEC 60384-4 LONG LIFE GRADE																																							

## K91 TYPE STANDARD RATINGS

Cap $\mu\text{F}$	$\varnothing \times L$ mm	Tan $\delta$ MAX 100 Hz 20°C	ESR TYP $m\Omega$ 100 Hz 20°C	Z TYP $m\Omega$ 10kHz 20°C	Ir a.c. A max 100 Hz 85°C	PART NUMBER stud and insert style excluded
680	51x79	0.08	97	75	5.11	K91400681_M0G079
680	51x105	0.08	97	75	5.74	K91400681_M0G105
1000	51x79	0.08	75	67	6.06	K91400102_M0G079
1000	51x105	0.08	75	67	6.87	K91400102_M0G105
1500	51x105	0.08	53	40	8.18	K91400152_M0G105
1500	63x105	0.08	53	40	9.29	K91400152_M0H105
2200	51x105	0.08	40	31	9.40	K91400222_M0G105
2200	63x105	0.08	40	31	10.70	K91400222_M0H105
2200	76x105	0.08	40	31	12.30	K91400222_M0J105
3300	63x105	0.08	25	16	13.60	K91400332_M0H105
3300	76x105	0.08	25	16	14.50	K91400332_M0J105
3300	76x143	0.08	25	16	16.80	K91400332_M0J143
4700	76x105	0.08	20	15	16.40	K91400472_M0J105
4700	76x143	0.08	20	15	19.50	K91400472_M0J143
5600	76x143	0.08	17	11	20.90	K91400562_M0J143
6800	76x143	0.08	15	10	22.20	K91400682_M0J143
10000	76x143	0.09	13	10	23.00	K91400103_M0J143
10000	76x214	0.09	13	10	28.70	K91400103_M0J214
15000	90x220	0.10	9	8	36.50	K91400153_M0L220

**RATED  
VOLTAGE  
VDC**

**400V**

Cap $\mu\text{F}$	$\varnothing \times L$ mm	Tan $\delta$ MAX 100 Hz 20°C	ESR TYP $m\Omega$ 100 Hz 20°C	Z TYP $m\Omega$ 10kHz 20°C	Ir a.c. A max 100 Hz 85°C	PART NUMBER stud and insert style excluded
680	51x79	0.08	97	75	5.11	K91420681_M0G079
680	51x105	0.08	97	75	5.74	K91420681_M0G105
1000	51x79	0.08	75	67	6.06	K91420102_M0G079
1000	51x105	0.08	75	67	6.87	K91420102_M0G105
1500	51x105	0.08	53	40	8.18	K91420152_M0G105
1500	63x105	0.08	53	40	9.29	K91420152_M0H105
2200	51x105	0.08	40	31	9.40	K91420222_M0G105
2200	63x105	0.08	40	31	10.70	K91420222_M0H105
2200	76x105	0.08	40	31	12.30	K91420222_M0J105
3300	63x105	0.08	25	16	13.60	K91420332_M0H105
3300	76x105	0.08	25	16	14.50	K91420332_M0J105
3300	76x143	0.08	25	16	16.80	K91420332_M0J143
4700	76x105	0.08	20	15	16.40	K91420472_M0J105
4700	76x143	0.08	20	15	19.50	K91420472_M0J143
5600	76x143	0.08	17	11	20.90	K91420562_M0J143
6800	76x143	0.08	15	10	22.20	K91420682_M0J143
10000	76x143	0.09	13	10	23.00	K91420103_M0J143
10000	76x214	0.09	13	10	28.70	K91420103_M0J214
15000	90x220	0.10	9	8	36.50	K91420153_M0L220

**RATED  
VOLTAGE  
VDC**

**420V**

## K91 TYPE STANDARD RATINGS

Cap µF	Ø x L mm	Tan δ MAX 100 Hz 20°C	ESR TYP mΩ 100 Hz 20°C	Z TYP mΩ 10kHz 20°C	I <sub>r</sub> a.c. A max 100 Hz 85°C	PART NUMBER stud and insert style excluded
470	51x79	0.08	159	120	4.36	K91450471_M0G079
680	51x79	0.08	114	105	4.94	K91450681_M0G079
680	51x105	0.08	114	105	5.57	K91450681_M0G105
1000	51x79	0.08	83	70	5.84	K91450102_M0G079
1000	51x105	0.08	83	70	6.60	K91450102_M0G105
1500	51x105	0.08	57	42	7.89	K91450152_M0G105
1500	63x105	0.08	57	42	8.97	K91450152_M0H105
2200	63x105	0.08	44	33	10.20	K91450222_M0H105
2200	76x105	0.08	44	33	11.90	K91450222_M0J105
2200	76x143	0.08	44	33	13.60	K91450222_M0J143
3300	76x105	0.08	30	18	14.00	K91450332_M0J105
3300	76x143	0.08	30	18	16.30	K91450332_M0J143
4700	76x143	0.08	21	15	18.80	K91450472_M0J143
5600	76x143	0.08	18	12	20.20	K91450562_M0J143
6800	76x143	0.08	16	11	21.30	K91450682_M0J143
8200	76x143	0.08	14	10	23.00	K91450822_M0J143
10000	76x143	0.09	13	10	23.10	K91450103_M0J143
10000	76x214	0.09	13	10	26.20	K91450103_M0J214
12000	76x214	0.09	13	10	26.20	K91450123_M0J214
15000	90x220	0.10	11	9	35.00	K91450153_M0L220

**RATED  
VOLTAGE  
VDC**

**450V**

PLEASE TO CONTACT OUR TECHNICAL SERVICE FOR MORE INFORMATION OR SPEC-IN ANALYSIS.

# PART NUMBER SYSTEM FOR SCREW TYPE CAPACITORS

New PART-NUMBER CODE in use since Sep 2010. Total length is 17 digits.  
Please see examples below and have a reference code from the standard ratings capacitors pages.

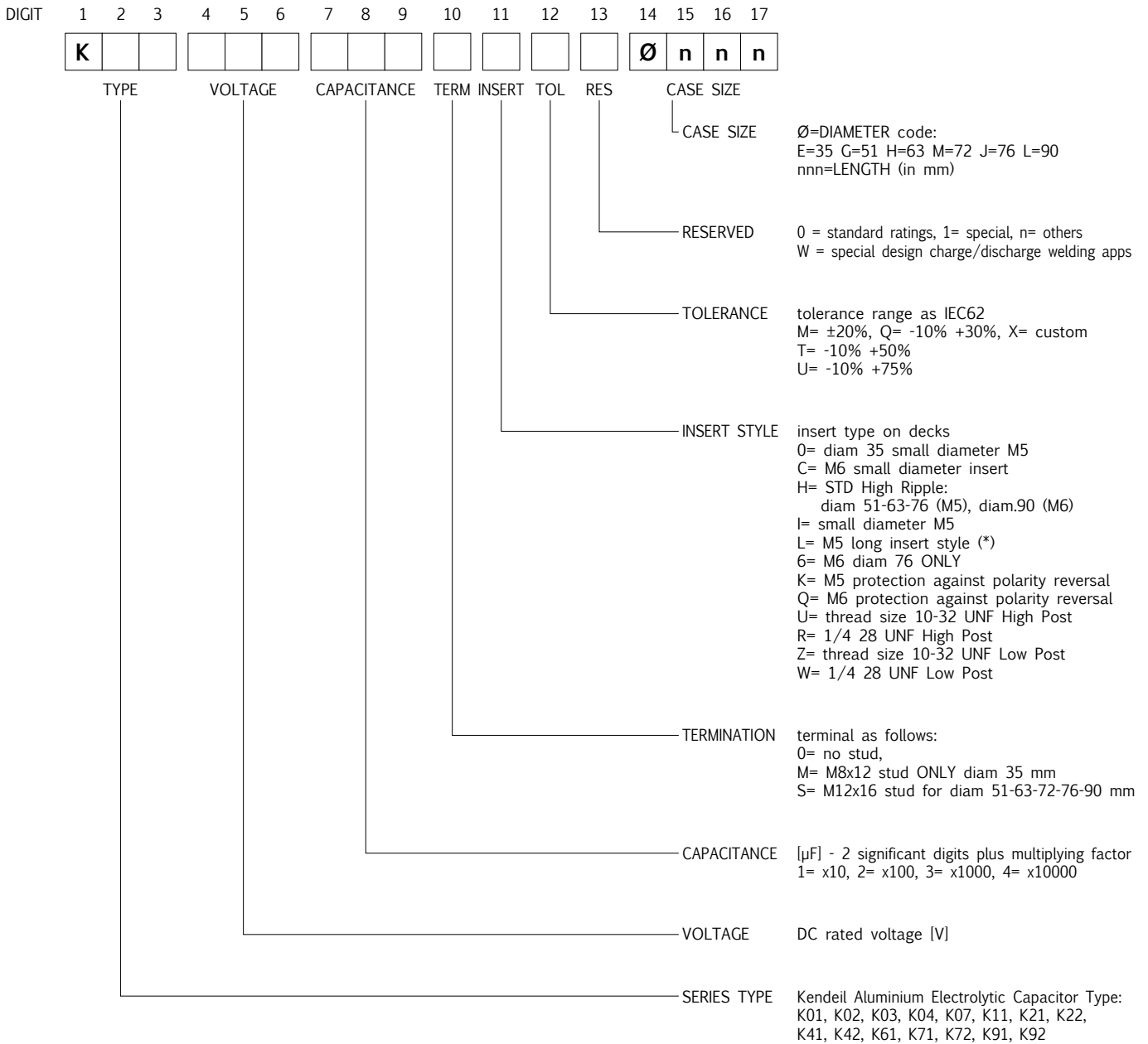

## EXAMPLES

K	0	1	1	0	0	2	2	3	0	H	M	0	H	1	0	5	K01 100V 22000µF, Hi ripple, -20%+20%, 63x105
K	0	1	0	6	3	2	2	3	S	H	Q	0	G	1	0	5	K01 63V 22000µF, stud M12x16, Hi rip. -10%+30%, 51x105
K	0	2	0	4	0	1	0	4	0	H	M	0	J	1	4	3	K02 40V 100000µF, Hi ripple, -20%+20%, 76x143

Specifications subject to change without notice

(\*) Note for INSERT STYLE

M5 long insert style dedicated to not insulated bus bar  
(+2 mm height versus STD High Ripple code)